

Technical supplement

Install MULTIPANEL as per MULTIPANEL balcony substrate waterproofing system installation guide.

MULTIPANEL



Decking onto MULTIPANEL

Step 1

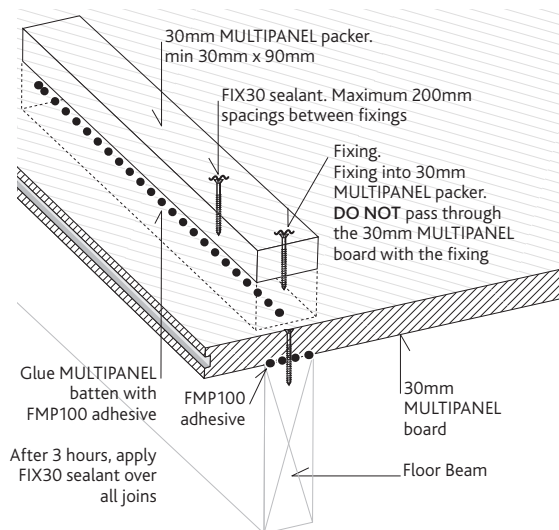

Step 2

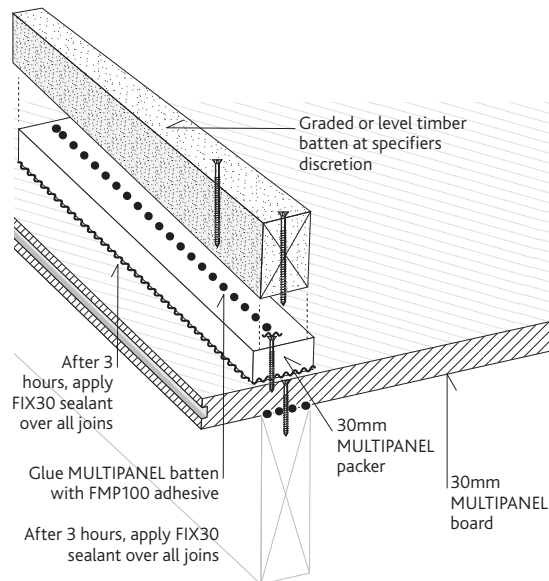

Step 3

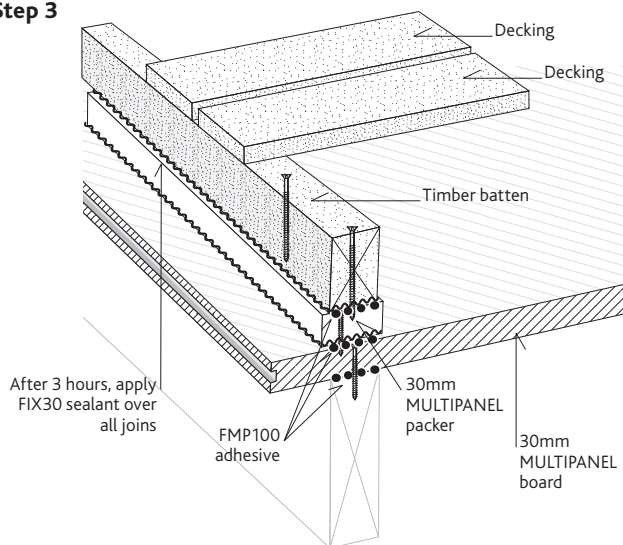

NOTE: Batten spacing's may vary, they must comply with the relevant codes and manufacturers specifications.

Warranty and conditions

The company warrants the MULTIPANEL Waterproof Balcony ("the product") for period of (10) years ("the warranty period") from the date of purchase, that it will be free from defects due to faulty manufacturing, and will be resistant to cracking, rotting, water, fire, and damage to the extent set out in the relevant MULTIPANEL published literature, and subject to compliance to the conditions set out below.

Conditions of warranty

The warranty is strictly subject to the following conditions (which are in addition to and do not displace the MULTIPANEL Terms and Conditions of Sale).

- a. The product and any other components of the system must be installed in accordance with the relevant MULTIPANEL literature current at the time of installation. Further to all other products including jointing and sealing systems, that are applied or used in conjunction with the product must be installed as per the relevant manufacturer's specifications at the time of installation.

- b. MULTIPANEL will not be liable for, and will not accept any breach of Warranty claims, unless the claimant provides proof of purchase within 30 days of the alleged defect becoming apparent.

- c. Under no circumstances is the Warranty transferable.

- d. MULTIPANEL will not be liable for defects arising from materials and components not supplied by MULTIPANEL, or the use of goods by a person in a manner not consistent with the recommendations made by MULTIPANEL.

- e. A claimant's sole remedy for breach of Warranty is (at the company's option) that MULTIPANEL will repair or replace the defect, pay the cost of replacement or rectification of the affected product, or supply replacement product.

- f. Under no circumstances will MULTIPANEL be liable for any damages or losses to property damage and personal injury, economic loss or loss of profits, arising from contract or negligence or howsoever arising. Without limiting the foregoing, MULTIPANEL will not be liable for any claims, damages or defects arising or in any way attributable to poor or defective workmanship, poor design and detailing, defective

materials, structural movement and/or movement of materials to which the product is attached to, acts of God including but not limiting to severe weather conditions or unusual climate conditions, normal wear and tear, or growth of any organism on the product.

Disclaimer

The recommendations in this literature are based on good building practice, but is not an exhaustive statement of all relevant information as the successful performance of the system depends on several factors outside the control of MULTIPANEL, for example the quality of workmanship and design.

MULTIPANEL Pty Ltd
 Level One 110 Mt Eliza Way
 Mt Eliza Victoria Australia 3930
 Phone +61 3 9787 2544
 Fax +61 3 9787 9582
 Email info@multipanel.com.au
www.multipanel.com.au